

General Dimensions: Floor Mounted Horizontal Shredders

Floor Shredder

SUPER-WIDE Floor Shredder

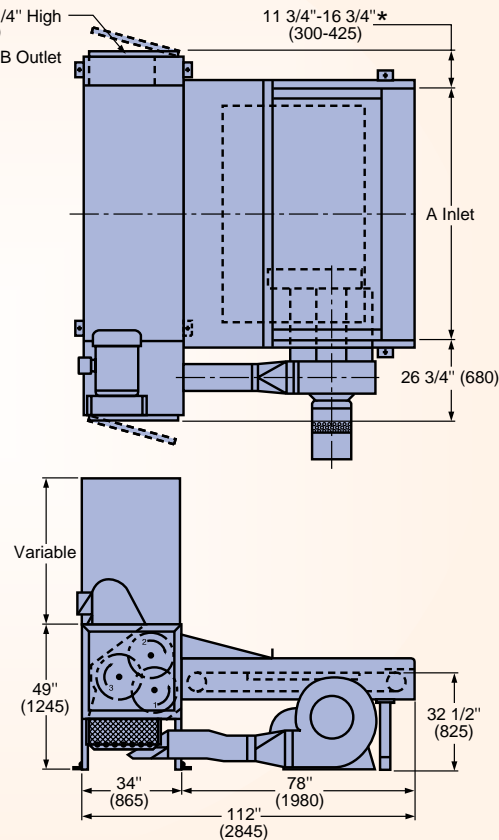
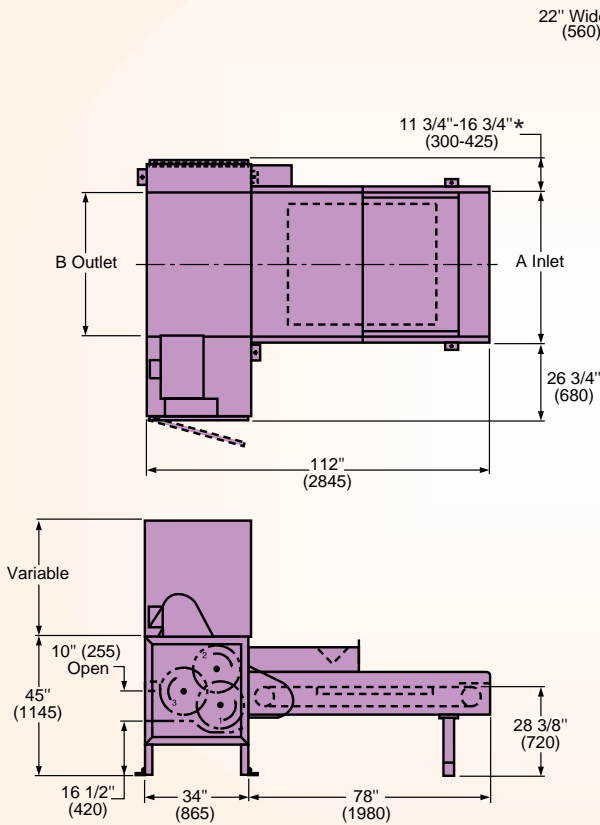

Shredder Width	Inches (mm)	36 (915)	48 (1220)	58 (1475)	72 (1830)	85 (2160)	100 (2540)	110 (2795)	120 (3050)
Inlet (A)	Inches (mm)	36 (915)	48 (1220)	58 (1475)	72 (1830)	85 (2160)	100 (2540)	110 (2795)	120 (3050)
Outlet (B)	Inches (mm)	36 x 10 (915 x 255)	48 x 10 (1220 x 255)	58 x 10 (1475 x 255)	72 x 10 (1830 x 255)	10 x 22 ‡ (255 x 560)	10 x 22 ‡ (255 x 560)	10 x 22 ‡ (255 x 560)	10 x 22 ‡ (255 x 560)
Approx. Wt.	Lbs. (Kg.)	2,600 (1175)	6,000 (2725)	6,300 (2875)	7,600 (3450)	9,200 (4175)	10,300 (4675)	10,700 (4850)	11,000 (4900)
Minimum Air Requirements Duct & Vol.	Inch/CFM (mm/M ³ /hr)	14 - 5,660 (360 - 9600)	15 - 6,500 (385 - 11000)	16 - 7,400 (410 - 12500)	18 - 9,000 (460 - 15300)	18 - 9,000 (460 - 15300)	20 - 11,200 (510 - 19000)	20 - 11,200 (510 - 19000)	20 - 11,200 (510 - 19000)
Typical HP (corrugated)		15 - 30	25 - 30	25 - 40	30 - 40	30 - 40	30 - 40	30 - 40	30 - 40
Corrugated Board Shredding Capacity**	Lbs/hr (Kg/hr)	4,000 (1815)	5,000 (2270)	7,500 (3400)	10,000 (4540)	12,000 (5500)	14,000 (6300)	14,000 (6300)	14,000 (6300)

Dimensions are approximate. Certified dimensions available upon request. BloApCo reserves the right to change specifications and dimensions without notice.

* This dimension may vary with change in shaft speed

** Shredding Capacity = Single wall corrugated board; A, B & C flute; 26# liner and medium; 2/50mm stacks.

‡ Super-Wide 85 - 120 Shredders utilize a pneumatic plenum with a side outlet.

MATERIAL HANDLING SYSTEMS

SHREDDERS

MATERIAL HANDLING FANS

TRIM CUTTERS

DIVERTERS

CYCLONES/SEPARATORS

RETURN AIR/DUST COLLECTORS

BALE TRANSFER

SEAL DRUM CONVEYORS

PLANT UPGRADES/EXPANSIONS

TURNKEY SYSTEMS

The Scrap Handling Technology of CHOICE

Since 1933

Visit our website bloapco.com

or

bloapco.com/shredders



BLOWER APPLICATION COMPANY, INC.

N114 W19125 Clinton Dr., PO Box 279
 Germantown, WI 53022-0279
 Fax 262.255.3446 • bac@bloapco.com
 800.959.0880 • 262.255.5580