

TRIM CUTTER

Model 7-7

For more information about this model, see Bulletin 991.

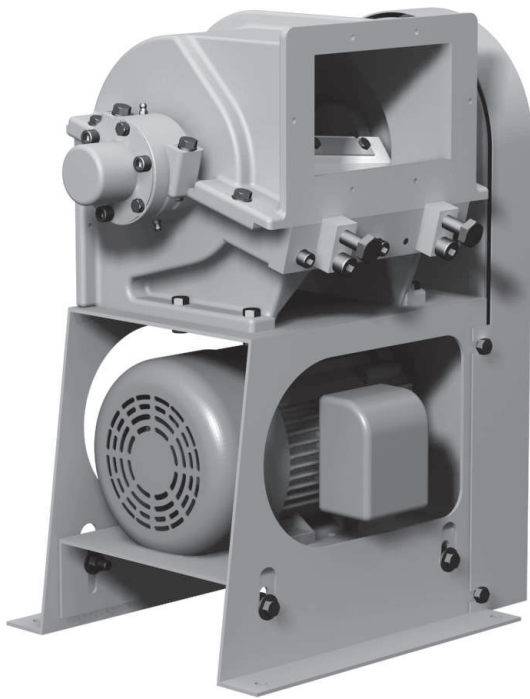

NEW GENERATION SHEAR ACTION FOR TOUGH FILMS AND FOILS MAINTAINS CUTTING EDGE WITHOUT IN-PLACE CYLINDRICAL GRINDING

Top Performance

The 7-7 trim cutter offers proven BloApCo design with new, innovative maintenance and operating features to achieve higher performance and economy. Driven by a 1-hp electric motor, the 7-7 efficiently cuts continuous film, foil and paper down to 1 mil thick, with varied knife profiles to permit cutting non-ferrous metals, thin films, foils and polycoated paper laminate. Wear resistant HCHC and NEOR knives handle abrasive polyesters and Mylar. Varied cutter arrangements are available to mate with slitting equipment. One cutter can handle multiple ribbons of trim, depending on weight and thickness, and reduce it for pneumatic conveying, baling, disposal or recycling. The 7-7 is well-suited to most web converting processes.

Precise Operation

Cutting with one stationary bed knife and two rotating knives, the 7-7 makes two cuts per revolution at speeds from 500 to 2,000 rpm. The unit passes 1,000 cfm of air at a static pressure loss of 2.0" wg at air velocities of 5,000 fpm. Adjustment screws in the rotor make the knives individually adjustable: knife clearance is easy to set, and the blades are easily removed for sharpening. Final "in-body" rotor grinding is not required. Precision tapered roller bearings eliminate end play and runout problems, keeping knife-edge clearances precise for longer. Open rotor design allows fast, free flow of cut material through the cutter housing.

Easy Installation

Installation of a 7-7 trim cutter is quick and simple: The cutter is factory-tested, tailored to your application, shipped completely assembled and ready to run.

CAPABILITIES

Materials

Light paper, plastic film and foil

Trim Width max

7½" (191 mm)

Caliper Range

1 mil to 20 mil

0.00100" to 0.02000"

0.0254 mm to 0.508 mm

Air Capacity

1,000 cfm 1,700 m³/hr

Static Pressure Loss

2.0" wg @ 5,000 fpm air velocity

Drive

V-Belt or Direct Drive

Cutting Action

Shear

Rotor speed

500 to 2,000 rpm

Weight

135 lbs (61 kg) with motor

Dimensions

L x W x H: 17" x 13¼" x 22½"

(431.8 mm x 336.5 mm x 571.5 mm)

FEATURES

- Rotor-mounted knife-adjustment screws for fast, easy setups
- Multiple knives: HCHC and NEOR
- Class "O" tapered roller bearings eliminate endplay and runout
- Rotor shaft supported by tapered roller bearings maintains rotor stability for long life
- Multiple drive arrangements: V-belt, direct drive and gear motor
- Open-rotor design facilitates free passage of air and material
- Multiple mounting arrangements
- Flanged inlet and outlets
- Multiple inlet positions
- 1 hp 3/60/460 volt TEFC motor is standard

OPTIONS

- Oil mist unit
- Safety disconnect switch
- Direct or gear motor drive
- Tandem rail mounting with BloApCo material-handling fans

Dimensions

Model 7-7

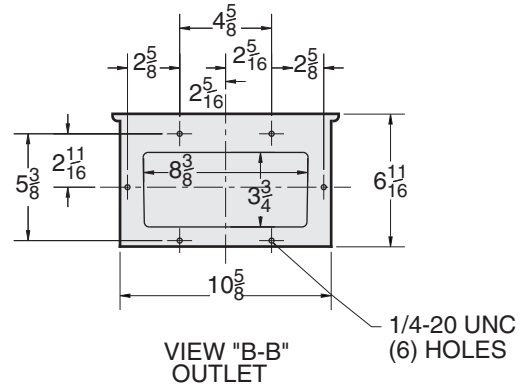
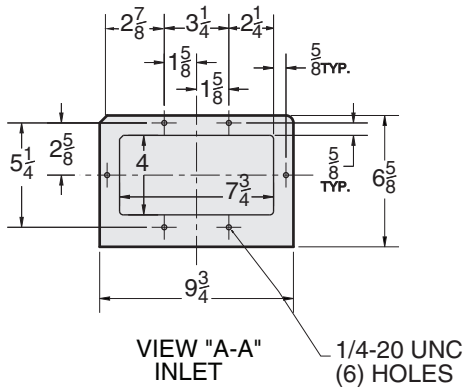
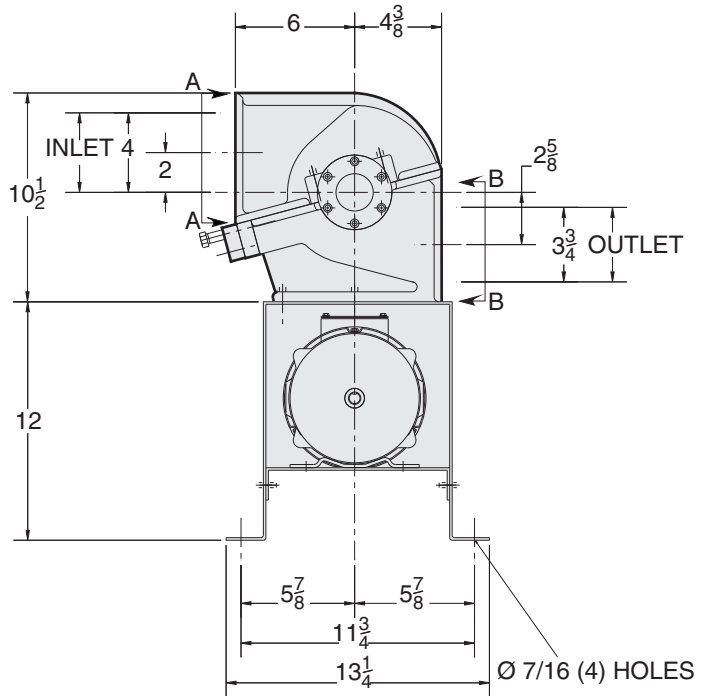
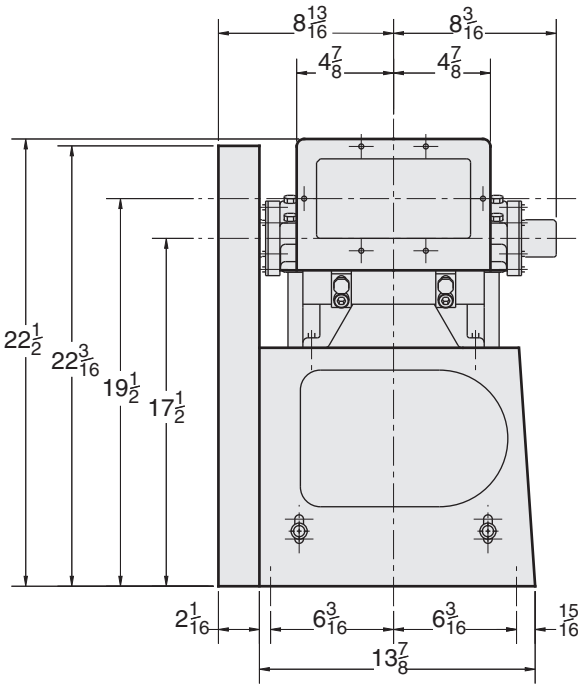

For more information about this model, see Bulletin 991

Revised 202009



Blower Application Company

N114 W 19125 Clinton Drive • P.O. Box 279 • Germantown, WI 53022-0279 • 800.959.0880 • 262.255.5580 • FAX: 262.255.3446 • bac@bloapco.com • bloapco.com