



HIGH-SPEED GRANULATORS

The ideal secondary granulator for a wide range of materials and precision size reduction.

High-speed granulators are designed for efficient secondary size reduction across a wide array of materials, delivering consistent and precise output.

A diverse range of models is available to meet varying application and throughput requirements, from small- and medium-duty machines, starting at 15 HP (1GM series) to super-duty, high-capacity equipment with motors up to 250 HP (1GSH series).

These machines are suitable for a wide range of applications, including pipes, film, rubber, cables, and hard or thick materials requiring fine particle output. Depending on specific requirements, the machines can be equipped with screen mesh sizes ranging from 2 to 60 mm, allowing precise control over final particle size.

Multiple rotor configurations are available at the time of equipment selection to achieve optimal performance. High-speed granulators can be equipped with standard or custom BloApCo control panels. All equipment includes a **1-year warranty**.



IDEAL FOR

- Plastic & Film
- Pipes & Cables
- Rubber
- RDF & Hard Materials
- Secondary Size Reduction



VERSATILE

Engineered for a wide range of materials and demanding application



DURABLE

Heavy-duty construction built for continuous, reliable operation



CONFIGURABLE

Multiple rotor and drive configurations to match specific needs



ADVANCED CONTROL

Standard and custom BloApCo control panels for optimal operation



PEACE OF MIND

All equipment is backed by a **1-year warranty**.

TECHNICAL SPECIFICATIONS

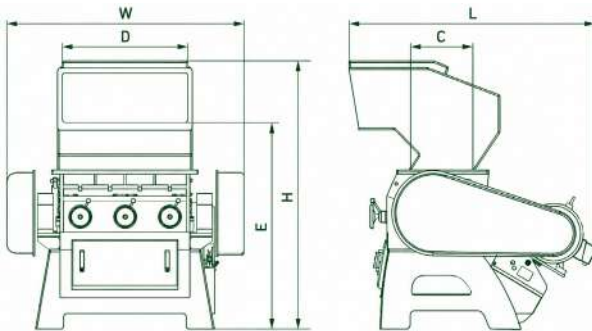

*Dependent on materials and feeding applications.
 **Screen size can be selected from 0.2 in (5 mm) to 2.5 in (60 mm) or larger. Standard screen size is 0.5 in (12 mm).
 ***Rotor sizes, designs, and number of knives are based on the application and can vary.
 ****Higher power rates are available on request.
 Overall dimensions are for illustration purposes. BloApCo will engineer and size the equipment based on the application and requirements.

Machine Model	1GL Starting at	1GM Starting at	1GH Starting at	1GSH Starting at
Estimated Capacity (T/Hr)*	1 - 3	1 - 8	4 - 10	12 - 20
L x W x H - Length x Width x Height (in)	45 x 37 x 81	54 x 53 x 102	84 x 84 x 142	95 x 92 x 172
C - Chamber (in)	13	17	29	33
D - Chamber (in)	22	22	40	50
E - Discharge Port Height (in)	60	74	103	128
Screen Mesh (in)**	0.2 - 2.5	0.2 - 2.5	0.2 - 2.5	0.2 - 2.5
Shaft Speed (RPM)	580	580	462	462
Rotor Knives (pc)***	3x2	3x2	5x2	5x2
Counter Knives (pc)	2x2	2x2	2x2	2x3
Motor Power**** HP (kw)	20 (15)	30 (22)	74 (55)	121 (90)
Gross Weight (lbs)	2,095	3,308	9,261	16,868





BUILT TO SHRED. BUILT TO PERFORM.

The Titan Series is engineered to efficiently shred a wide range of materials, reducing volume, improving handling, and maximizing value.

PLASTIC

Engineered plastic, PC, ABS, POM, PVC, PA, PP, PE, (UHMW, HD, PET, HI), and more



METAL

Aluminum, copper, steel, cans, sheets, drums, vehicle body shells, and more



WOOD

Timber pallets, construction waste, furniture, and more



WEEE

Waste electrical and electronic equipment, solar panels, batteries, and more



TIRES & RUBBER

Tires, rubber products, conveyer belts, hoses, and more



FOOD

Poultry and slaughtered products, food waste, and more



MEDICAL

Medical waste in general, pharmaceutical products, and more



TEXTILE

Carpeting, clothing, natural or synthetic fibers, fabrics, and more



PAPER

Paper, corrugated cardboard, cartons, and more



WIRE

Wire, cable, piping, metallic and non-metallic materials, and more



WHY CHOOSE TITAN SERIES?



ENGINEERED DURABILITY

Heavy-duty construction built to handle the most demanding applications



VERSATILE SOLUTIONS

A full range of shredders and granulators for diverse industries and materials



ADVANCED CONTROL

Smart, customizable control systems for optimal performance and safety



TRUSTED SUPPORT

Dedicated support and service to keep your operations running strong



ADVANCED SOLUTIONS.
POWERFUL RESULTS.

LET'S FIND THE RIGHT SOLUTION FOR YOUR APPLICATION.

Contact our team today to learn how the Titan Series powers your performance.



bloapco.com



info@bloapco.com



(800) 959-0880



N114 W19125 Clinton Dr
PO Box 279
Germantown, WI
53022-0279